

SATAKE MULTI S MIXERS

S3-S6 Series

A series of mixers that matching work on-site

For all kinds of mixing processes.

Chemical, Pharmaceutical, Food, Drink, Paper manufacturing,
Wastewater treatment, Energy, etc.

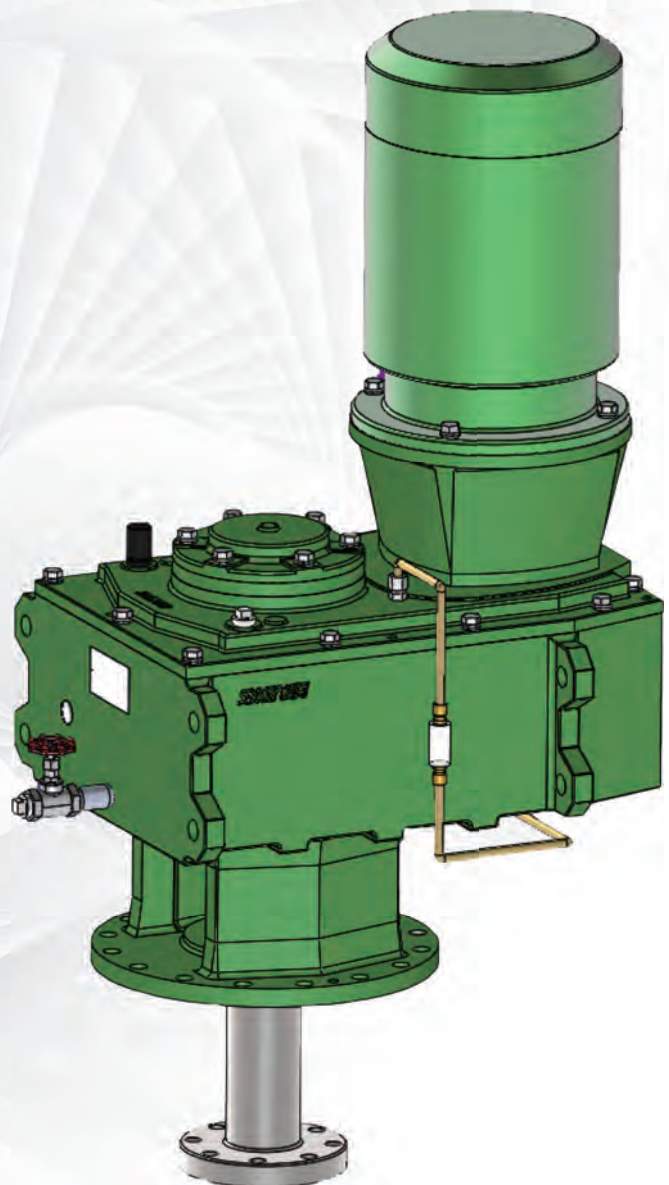

Quality, Efficient, Safe, and Environmental-friendly. Satake Multi-S Mixers Undergo Major Renewal to Keep Up with the Trends!

Since its establishment in 1920, Satake has been engaged in research and development of mixing technology, consistently. We have earned good reputations as a manufacturer of high-performance and high-quality mixers by delivering efficient mixers to our customers. Currently, we are expanding our business to other Asian countries, and also establishing a platform as a mixing expert in Asia and in Japan as well.

The new multi-S mixers (S3~S6 series), which have gone through a major renewal, offer the best mixing performance with less energy and less loads (work efficiency and environmental-friendly). We are pleased to introduce you to this new generation of highly efficient mixers.

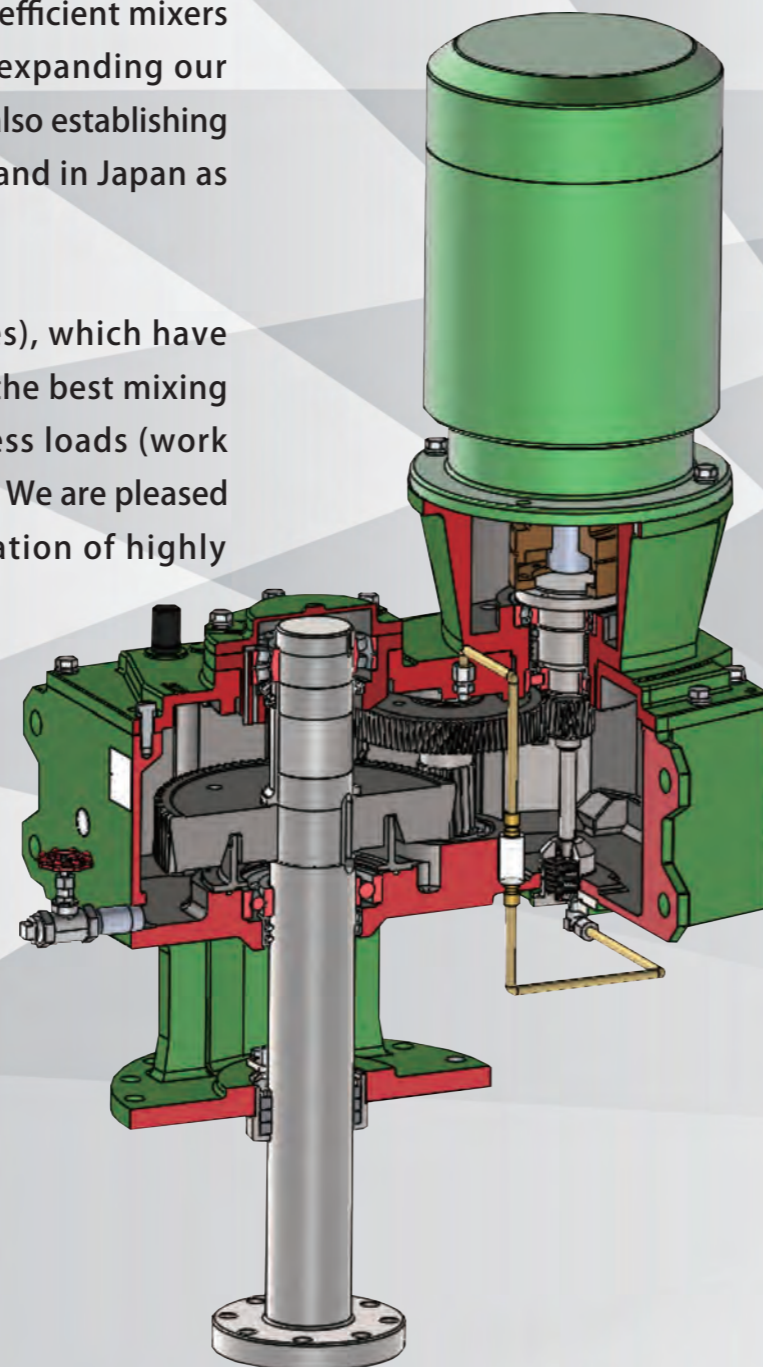

**A precise lineup to meet various needs.
Easy to use, including workability and safety, and
environmental-friendly.
The accumulation of 100 years of Satake's mixing
technology is now here.**

Features

1. Downsizing of the mixer was achieved by devising the gear arrangement.
2. Major cost reductions have been achieved through complete commonality of parts. (Compared to our previous model)
3. 17 combinations of impeller speed and motor output are available. Applicable to various mixing applications.
4. Commercial motors can be installed.
5. Drywell design is also available as a new option. This contributes to environmental-friendly.
6. The main body structure has been revised for easier maintenance.
7. High performance of "Supermix®" impellers are also available. Please consult us for selection!

◎ Drywell design ※ Option

The gears in a mixer are important components that transmit power and rotation. Thus, lubrication with oil is essential. However, in the unlikely event of an oil leak from the gear box, contamination of the process fluid and adverse effects on the surrounding environment can occur. In this model, a newly constructed "dry-well design" is applied with an oil dam on the shaft seal and a pump that sprays oil on the sliding part and gear tooth surface to prevent oil leakage.

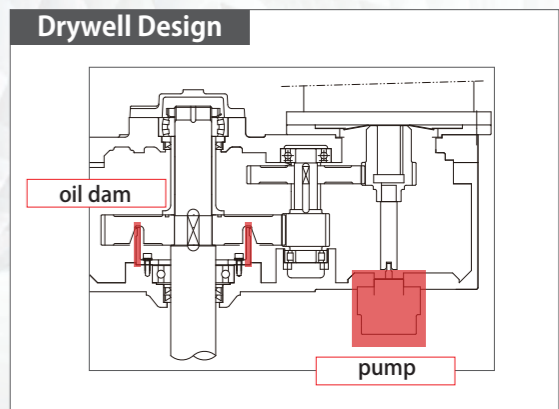

◎ Environmental-friendly and Maintenance

A mixer requires periodic maintenance, repair, and replacement of parts. If disassembly and assembly are complicated, the risk of accidents will increase. This mixer has been developed by utilizing the benefits of the <<Drywell Design>> and reflecting the opinions of on-site users, as well. Additionally, it is also has been devised in many ways, in order that work can be performed easily and safely.

- Completely eliminates oil leakage from the shaft seal.
- Less oil consumption. (Compared to our previous model)
- Eliminates the need for daily inspections for oil leaks. (Compared to our previous model)
- The maintenance work area is concentrated on one surface.
 - One-side maintenance improves work efficiency.
 - Various piping designs are also made easier.

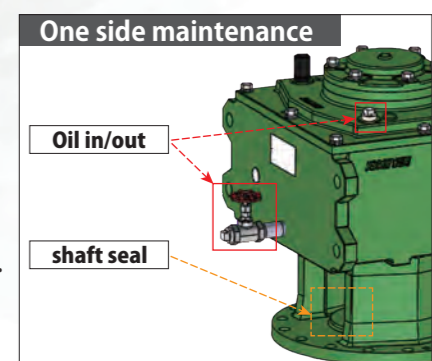

SATAKE MULTI S MIXERS S3~S6 SERIES

C O N T E N T S

Features	2
Model Coding / Safety and Quality Control	3
Model Variations	4
Standard Dimensional Drawings-Top-mount Type	5
Standard Dimensions-Top-mount Type	6
Standard Dimensional Drawings and Dimensions-Side-mount Type	7
Impeller / Impeller Performance	8
Shaft Sealing Systems- Top-mount Type	9
Shaft Sealing Systems- Side-mount Type	10
Swing Replacement Mechanical Seal (E1 Type)	11
Standard Dimensional Drawings of E1 Type	13
Standard Dimensions for E1 Type	14

Consult us for model selection!

Model Coding

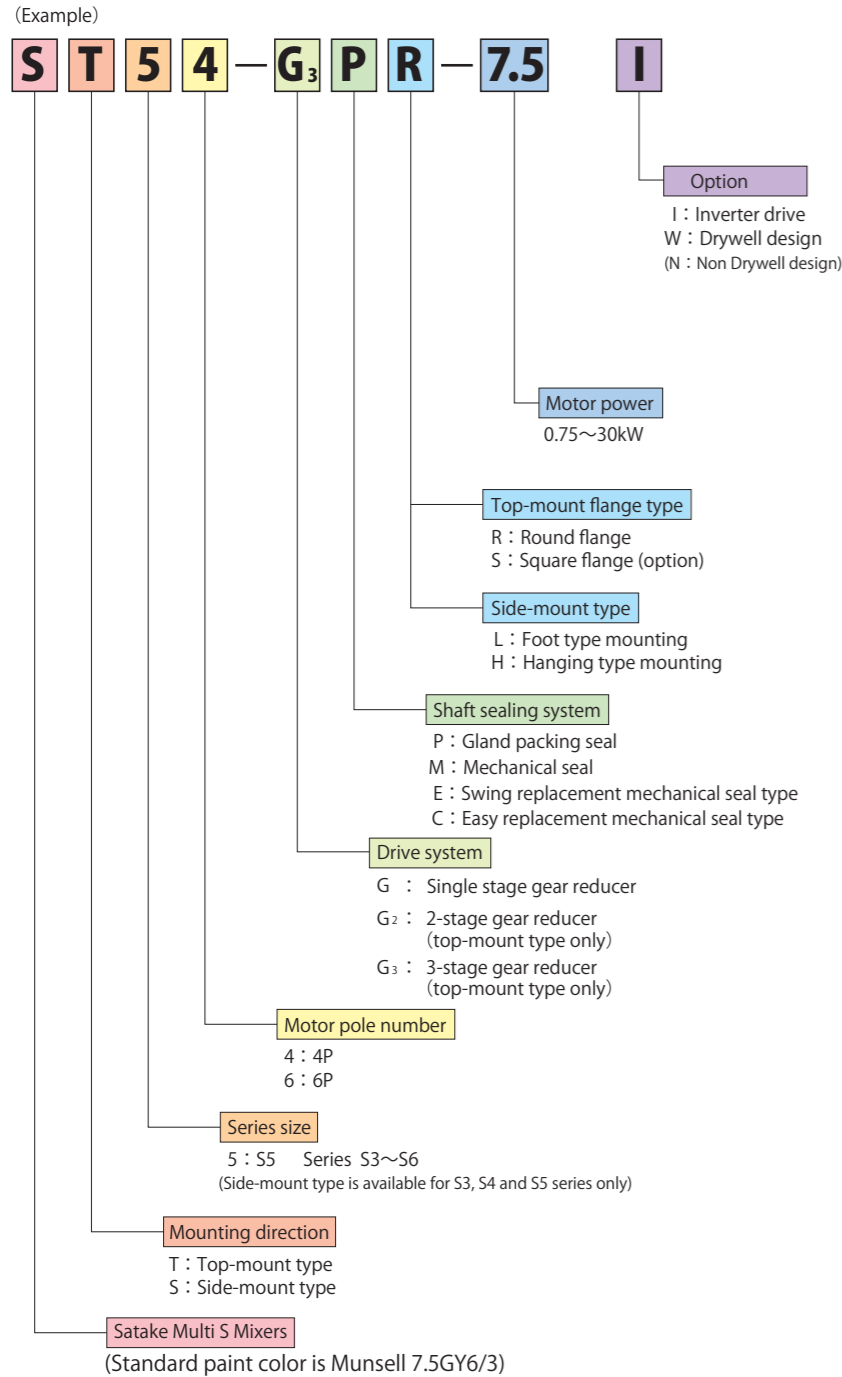

Safety and Quality Control

SATAKE mixers are labeled with the "▲" mark. This represents Satake's stance of proactively practicing safety management and quality assurance systems, including the PL Law. In the quality assurance system, each department is in charge of each step of operation from product development to sales and after-sales service, and each department has also established its own quality program.

We have many experienced staffs, including those in the R&D department. However, it is necessary to have a production system equipped with functionalities that can realize our knowledge and technology as a platform to ensure the quality of our products. The SATAKE mixers are manufactured at a production site equipped with high-tech facilities including FMS and inspection equipment, unique production systems and a complete safety management as well.

We deliver the SATAKE Multi S Mixers with comprehensive management system that can be used with peace of mind.

- Operation that the liquid level passes over impeller position
- Empty operation

What is the operation that the liquid level passes over impeller position?

In case of increasing or decreasing the liquid while running the mixer, the bottom impeller is from the stable condition without creating steady suction vortex (at the MIN.L.L. on the drawing) to the fully exposed in air condition (or conversely) within 10 minutes. Failure to do so may cause bending of the shaft. (Please check shaft runout, looseness of bolts, etc.)

What is empty operation?

A condition in which the bottom impeller is completely exposed in air due to operation through the liquid level. In the case of empty operation, there is no vibration control effect from the liquid, which can lead to shaft bending. Please stop the operation within 10 minutes.

Model Variations-Top-mount Type (50Hz)

		Motor power (kW)											
		Speed (min ⁻¹)	0.75	1.5	2.2	3.7	5.5	7.5	11	15	18.5	22	30
Single stage reducer	350					S3	S3	S4	S4	S5	S5	S5	
	280					S3	S3	S4	S4	S5	S5	S5	
	230(*)				S3	S3	S4	S4	S5	S5	S5		
	190(*)				S3	S3	S4	S4	S5	S5	S5		
2-stage reducer	155			S3	S3	S4	S4	S5	S5	S6	S6	S6	
	125		S3	S3	S3	S4	S4	S5	S5	S6	S6	S6	
	100		S3	S3	S4	S4	S4	S5	S5	S6	S6	S6	
	84		S3	S3	S4	S4	S5	S5	S6	S6	S6		
	68		S3	S3	S4	S5	S5	S5	S6	S6	S6		
56										S6			
3-stage reducer	56	S3	S3	S4	S4	S5	S5	S6	S6				
	45	S3	S3	S4	S5	S5	S5	S6	S6				
	37	S3	S4	S4	S5	S5	S6	S6					
	30	S3	S4	S4	S5	S6	S6						
	25	S3	S4	S5	S5	S6	S6						
	20	S4	S4	S5	S5	S6	S6						
	16.5(*)	S4	S5	S5	S6	S6							
13.5(*)	S4	S5	S5	S6									

In the table: (*) indicates the use of 6P motor.

Model Variations-Top-mount Type (60Hz)

		Motor power (kW)											
		Speed (min ⁻¹)	0.75	1.5	2.2	3.7	5.5	7.5	11	15	18.5	22	30
Single stage reducer	350					S3	S3	S4	S4	S5	S5	S5	
	280					S3	S3	S4	S4	S5	S5	S5	
	230(*)				S3	S3	S4	S4	S5	S5	S5		
2-stage reducer	190			S3	S3	S4	S4	S5	S5	S6	S6	S6	
	155			S3	S3	S4	S4	S5	S5	S6	S6	S6	
	125		S3	S3	S3	S4	S4	S5	S5	S6	S6	S6	
	100		S3	S3	S4	S4	S4	S5	S5	S6	S6	S6	
	84		S3	S3	S4	S4	S5	S5	S6	S6	S6		
68										S6	S6		
3-stage reducer	68		S3	S3	S4	S5	S5	S5	S6				
	56	S3	S3	S4	S4	S5	S5	S6	S6				
	45	S3	S3	S4	S5	S5	S5	S6	S6				
	37	S3	S4	S4	S5	S5	S6	S6					
	30	S3	S4	S4	S5	S6	S6						
	25	S3	S4	S5	S5	S6	S6						
	20(*)	S4	S4	S5	S6	S6							
16.5(*)	S4	S5	S5	S6	S6								

In the table: (*) indicates the use of 6P motor.

Model Variations-Side-mount Type (50/60Hz)

		Motor power (kW)								
		Speed (min ⁻¹)	3.7	5.5	7.5	11	15	18.5	22	30
Single stage reducer	50Hz	350		S3	S3	S4	S4	S5	S5	S5
		280		S3	S3	S4	S4	S5	S5	S5
		230(*)	S3	S3	S4	S4	S5	S5	S5	
	60Hz	350		S3	S3	S4	S4	S5	S5	S5
		280	S3	S3	S4	S4	S5	S5	S5	
		230(*)	S3	S3	S4	S4	S5	S5	S5	

• S3 series: Motor can be mounted up to 132MJ (flange outer diameter φ300)

• S4 series: Motor can be mounted up to 160LJ (flange outer diameter φ350)

• S5 series: Motor can be mounted up to 200LJ (flange outer diameter φ450)

In the table: (*) indicates the use of 6P motor



Compact, lightweight, and low-cost

... the demand of the generation has been realized.

Standard Dimensional Drawings-Top-mount type

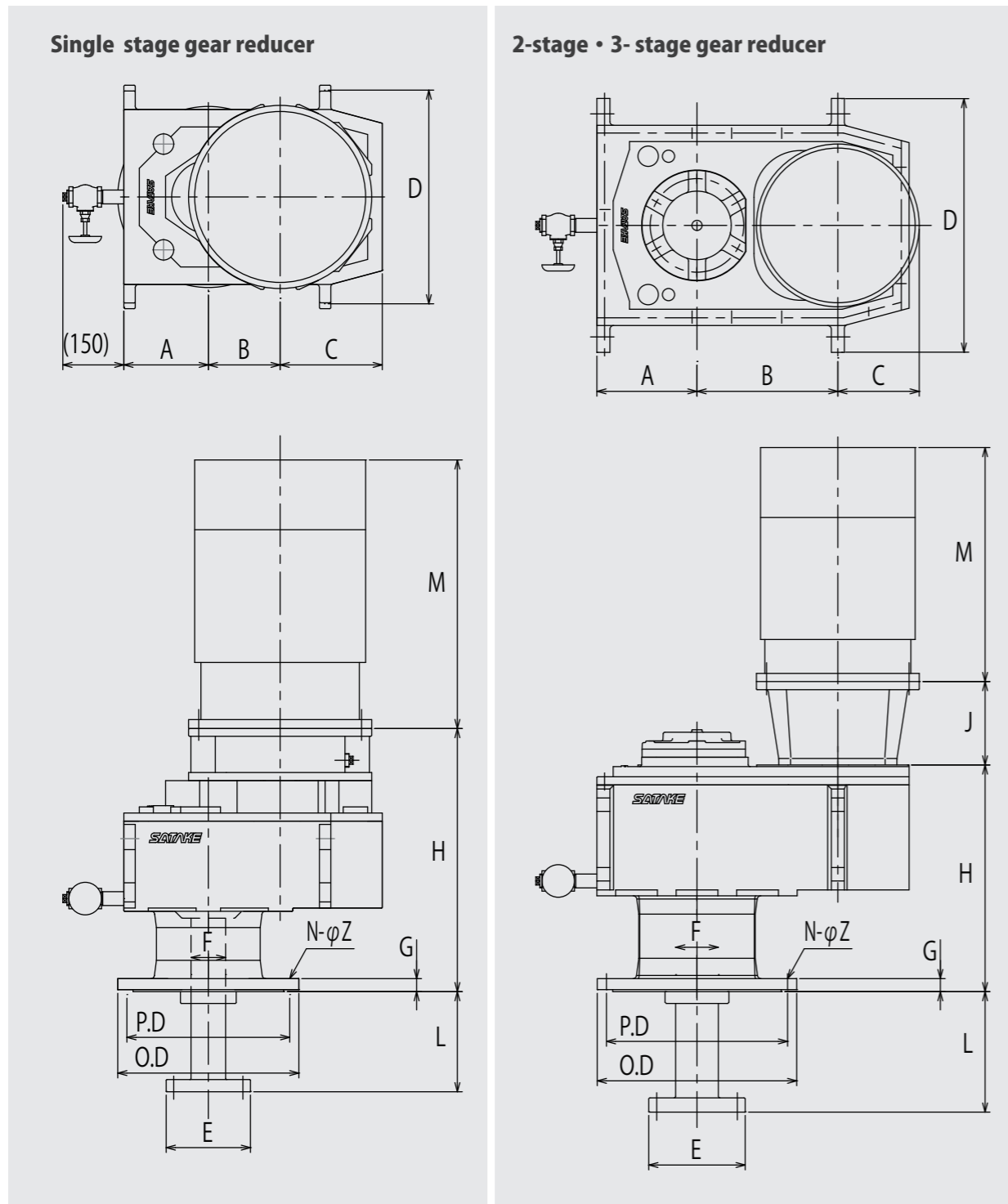

Standard Dimensions-Top-mount Type

	Series	Motor Power (kW)		Dimension(mm)																	Mixer Body Estimated Weight (kg)																				
		4P	6P	O.D	P.D	O.S	P.S	G	N	ΦZ	N.S	ΦZS	F	E	L	H	J	A	B	C	D	M	Est. Weight	Motor																	
Single Stage Gear Reducer	S3	5.5	3.7	350	310	□350	□305	24	12	23	4	24	55	137	200	459	—	162	119	214	426	400	240	(80)																	
		7.5	5.5																			400	240	(80)																	
	S4	11	7.5	400	355	□400	□350	26	12	25	4	24	65	157	200	524	—	175	138	216	480	485	335	(110)																	
		15	11																			525	355	(130)																	
	S5	18.5	15																			575	560	(195)																	
		22	18.5	445	400	□445	□395	28	16	25	4	26	85	207	250	579	—	208	176	251	549	575	560	(195)																	
30		22																			615	590	(225)																		
2-stage Gear Reducer · 3-stage Gear Reducer	S3	0.75	—	350	310	□350	□305	24	12	23	4	24	55	137	200	364	—	162	224	109	426	260	160	(17)																	
		1.5	—																			312	165	(24)																	
		2.2	—																			328	175	(30)																	
		3.7	—																			355	190	(48)																	
	S4	0.75	—	400	355	□400	□350	26	12	25	4	24	65	157	200	391	—	175	239	115	480	260	210	(17)																	
		1.5	0.75																			312	215	(24)																	
		2.2	1.5																			328	225	(30)																	
		3.7	—																			355	240	(48)																	
		5.5	—																			400	275	(80)																	
		7.5	—																			400	275	(80)																	
	S5	2.2	1.5	445	400	□445	□395	28	16	25	4	26	85	207	250	453	—	208	287	141	549	328	345	(30)																	
		3.7	2.2																			355	360	(48)																	
		5.5	—																			400	390	(80)																	
		7.5	—																			400	390	(80)																	
		11	—																			485	415	(110)																	
	15	—	525	435	(130)																																				
	S6	5.5	3.7	490	445	□490	□435	28	16	25	4	28	105	237	300	553	—	251	346	175	624	400	590	(80)																	
		7.5	5.5																			400	590	(80)																	
11		—	485																			610	(110)																		
15		—	525																			630	(130)																		
18.5		—	490																			445	□490	□435	28	16	25	4	28	105	237	300	553	205	251	346	200	624	575	750	(195)
22		—																																					615	850	(225)
30	—																																								

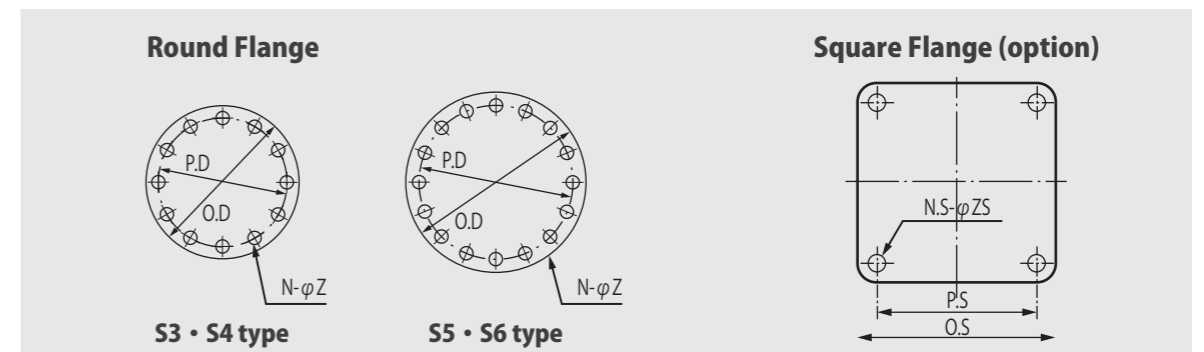

We are constantly committed to improve the quality of our products, thereby the design and specifications of our products may differ from those shown in the catalog. Please understand this in advance.

Standard Dimensional Drawings and Dimensions-Side-mount Type

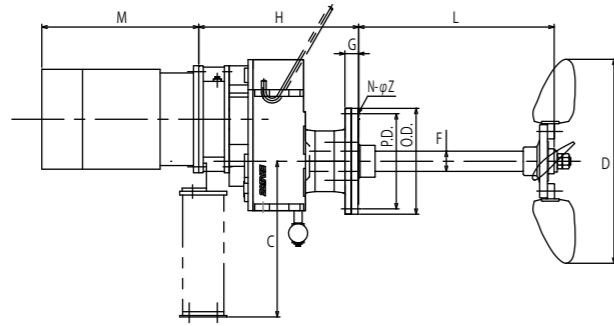

Series	Speed (min ⁻¹)	Motor Power (kW)	Pole (P)	Dimension (mm)										Mixer Body Estimated Weight (kg)				
				O.D	P.D	O.S	P.S	G	F	L	H	C	M	D	Est. Weight	Motor		
Single Stage Gear Reducer	S3	350	5.5	4	350	310	12	23	47	55	550	459	745	400	500	275	(80)	
			7.5	4										400	530	275	(80)	
		280	5.5	4										400	530	275	(80)	
			7.5	4										400	600	280	(80)	
			3.7	6										400	500	275	(80)	
			5.5	6										400	530	275	(80)	
			3.7	6										400	590	280	(80)	
			5.5	6										400	650	285	(80)	
	230	5.5	6	400	650	285	(80)											
		S4	350	11	4	400	355	12	25	51	65	650	524	885	485	590	380	(110)
				15	4										525	630	405	(130)
			280	11	4										485	650	385	(110)
				15	4										525	680	410	(130)
		7.5		6	485										600	390	(110)	
11		6		525	650										405	(130)		
7.5		6		485	680										380	(110)		
11	6	525		740	420										(130)			
S5	350	18.5	4	445	400	16	25	53	85	850	579	994	575	650	650	(195)		
		22	4										575	680	650	(195)		
		30	4										615	710	690	(225)		
		18.5	4										575	710	660	(195)		
		22	4										575	740	660	(195)		
		30	4										615	790	700	(225)		
	280	15	6										575	680	650	(195)		
		18.5	6										615	710	690	(195)		
		22	6										615	740	690	(225)		
		15	6										575	790	670	(195)		
		18.5	6										615	830	700	(195)		
		22	6										615	860	710	(225)		
		230	18.5										6	615	830	700	(195)	
			22										6	615	860	710	(225)	

Nozzle Dimensions and Dimensional Drawings for Side-mount Type

Please refer to the following table when installing the side-mount type to a steel mixer tank. If the mixer tank is thin and insufficient in strength, it is necessary to reinforce it with a hanger bar or support leg.

(Unit : mm)

Series	Nozzle Size	A	B	C	D	E	F	G	H	J	t	Z
S3	225A	350	310	241.8	50	9.0	750	9	120	22	12	23
S4	250A	400	355	267.4	55	9.3	850	9	130	24	12	25
S5	300A	445	400	318.5	55	10.3	950	12	150	24	16	25

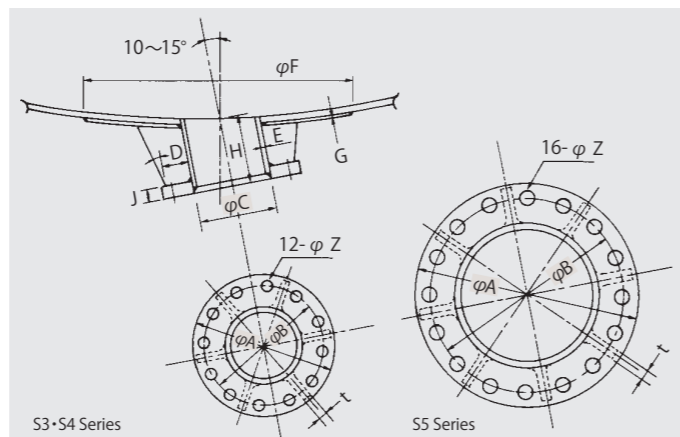

Mixing Control Technology **Super-MIX Series**

Impellers are the embodiment of Satake's commitment to more efficient mixing.

Impeller is the most important element of a mixer. This mixer is equipped with a single stage of 3-bladed axial flow blade as a standard for general use, which was developed using high-tech measurement systems such as a Laser Doppler Velocimeter and a novel system for low Reynolds number range. In addition, the superior combinations of the power number (Np value) and the discharge flow number (Nqd value) enable a single stage HR320 impeller to demonstrate performance greater than that of a dual-stage 4-bladed pitched paddle impeller.

HR320 Impeller

The HR320 impeller features blade with advanced angle promotes fluid flow to the center of the tank by mounting it at the off-center position. Additionally, the curvature angle is slightly changed towards to the tip of the blade. This design is expected to minimize flow separation at the back of the blade and generate a high discharge flow rate. The discharge performance is also improved by more than 35% compared to the conventional 4-bladed pitched paddle impeller, thereby contribute to energy saving.

Direct welding to the mixing shaft was employed instead of key finishing for the steel-plate welded blade-boss. This allows the mixing shaft to be inserted straight from the mounting flange into the mixing tank, making it easier to install into the tank. (HR320, HR320S)

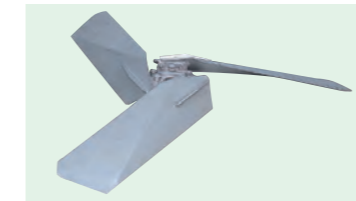

Flow pattern at near impeller blade by PTV image processing

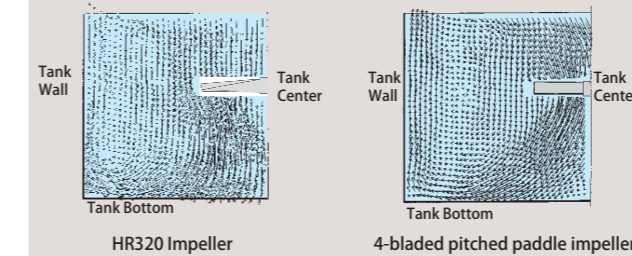

HR320S Impeller

The HR320S impeller features not only the effect of the advanced blade, but also enables to control pressure and flow separation at the blade surface due to the high angle of attack of the blade. Additionally, in order to achieve a high discharge flow rate, the double blade design has the same effect as the gap flaps and leading-edge slats used in aircraft.



MR205 Impeller

The MR205 features a large pressure difference which is generated between the positive pressure area in front of the main blade and the negative pressure area on the secondary blade. This pressure difference creates a strong discharge flow in the radial direction even in highly viscous liquids. In addition, by locating a large diameter area at the bottom of the main blade, a strong upward flow is generated from the bottom of the tank going up to the liquid surface.



Flow Pattern of MR205 Impeller

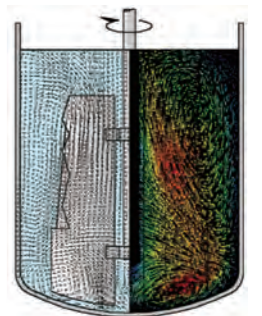

Comparison results of the fluid flow analysis using P.T.V. and numerical analysis using C.F.D.

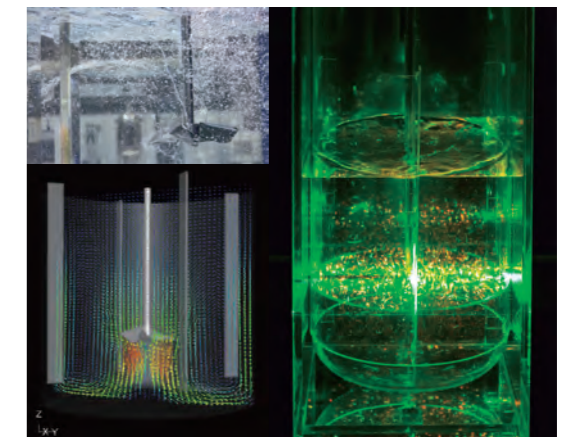

Comparison on the impeller performance

Impeller type	Ratio of power number	Ratio of discharge flow number	Ratio of discharge flow per unit power	Ratio of required power per unit discharge flow number
	Np [ratio]	Nqd [ratio]	Nqd/Np ^{1/3} [ratio]	Np/Nqd ³ [ratio]
4-bladed pitched paddle (θ=45°)	Standard value = 1	Standard value = 1	Standard value = 1	Standard value = 1
HR320 Impeller	0.38	0.98	1.35	0.40
HR320S Impeller	0.47	0.95	1.22	0.55

*Comparison on the performance of each impeller compared to the 4-bladed pitched paddle at standard value = 1.

Wide variety of shaft sealing systems are available

Shaft Sealing System -Top-mount Type

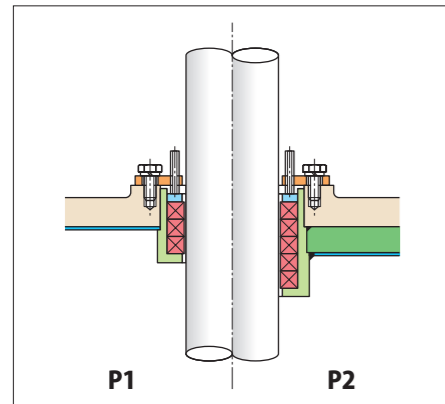

- Gland Packing Seal**
- P1 type**
- Inside tank temperature: 120°C or less
 - Inside tank pressure: Atmosphere
 - It is not designed for a pressure-tight seal, but it is ideal as a simple seal.
- P2 type**
- Inside tank temperature: 120°C or less
 - Inside tank pressure: 3×10^{-2} MPaG (0.3 kgf/cm²G) or less
 - It is used for low pressure condition in the tank.

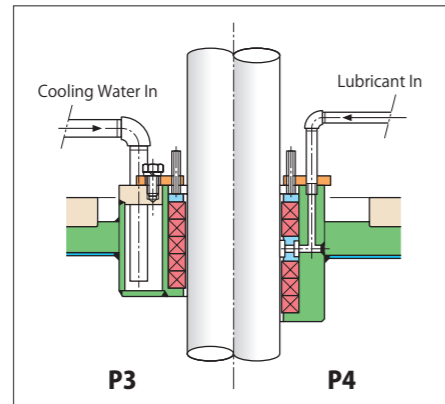

- Gland Packing Seal**
- P3 type**
- Inside tank temperature: 120°C or less
 - Inside tank pressure: 3×10^{-2} MPaG (0.3 kgf/cm²G) or less
 - It is ideal for inside tank temperature above 121°C
- P4 type**
- Inside tank temperature: 120°C or less
 - Inside tank pressure: 0.1 MPaG (1.0 kgf/cm²G) or less
 - Inject lubricant periodically in the midsection of the gland packing. Seal the leaking fluid with the packing at the back of the lantern ring and the lubricant with the packing at the front.

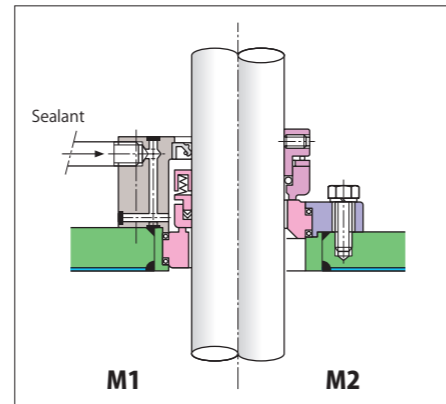

- Single Mechanical Seal (for vacuum tank)**
- M1 type**
- Inside tank temperature: 100°C or less
 - Inside tank pressure: 3×10^{-2} MPaG (0.3 kgf/cm²G) or less
 - It is generally used for vacuum type mixing tanks that are not tolerant of leaks and demonstrate excellent-sealing performance.
- Dry Mechanical Seal**
- M2 type**
- Inside tank temperature: 150°C or less
 - Inside tank pressure: F.V.~0.19 MPaG (1.9 kgf/cm²G) or less
 - This type of mechanical seal does not require sealant. It is used to prevent sealant from entering the tank, thereby prevent sealant from reacting with the gas or liquid in the tank.

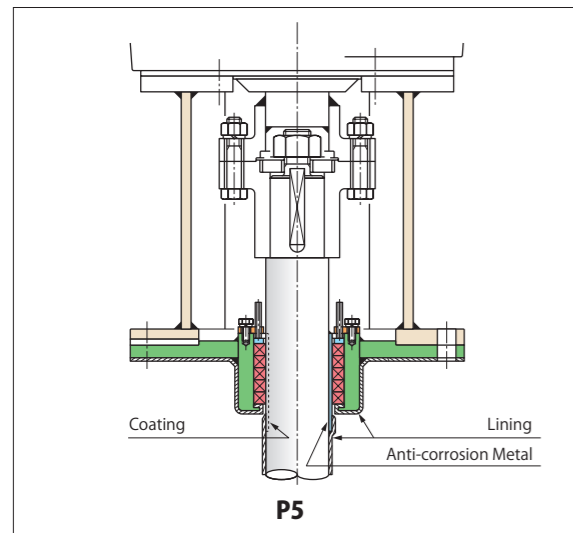

- Gland Packing Seal (Lining and coating of various parts in contact with liquid and gas)**
- P5 type**
- Inside tank temperature: 120°C or less
 - Inside tank pressure: 3×10^{-2} MPaG (0.3 kgf/cm²G) or less
 - Various types of metal lining and coatings (hastelloy, stellite, colmonoy, hard chrome plating, ceramic) are used on the sliding parts of the gland packing.

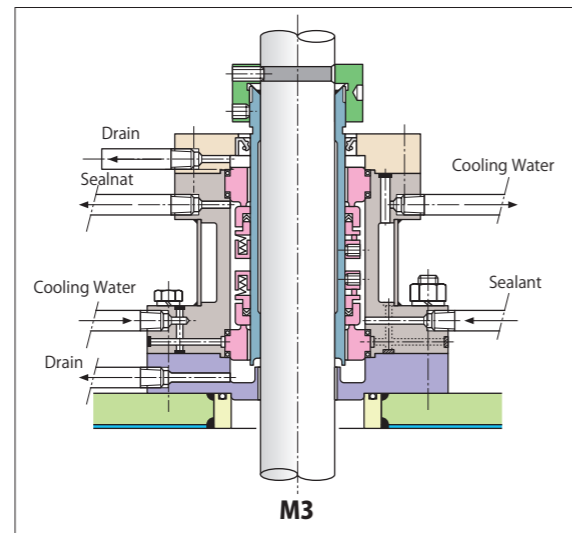

- Double Mechanical Seal**
- M3 type**
- Inside tank temperature: 300°C or less
 - Inside tank pressure: F.V.~0.99 MPaG (9.9 kgf/cm²G) or less (In case the inside tank pressure exceeding 0.99 MPaG, we will consider it on a case-by-case basis.)
 - It is generally used in applications where leakage is not tolerated, and provides excellent sealing performance even under high temperature, low temperature, high pressure, and vacuum conditions.

Shaft Sealing Systems-Side-mount Type

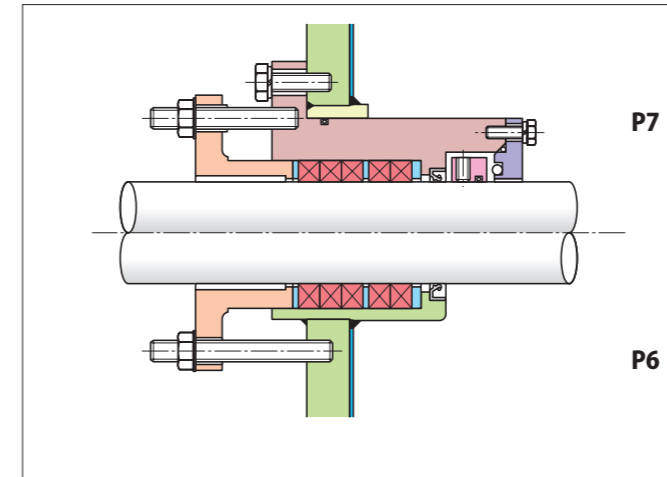

- Gland packing seal (temporary seal system)**
- P7type**
- Inside tank temperature: 120°C or less
 - Inside tank pressure: 0.1 MPaG (1.0 kgf/cm²G) or less
 - Gland packing can be replaced while tank is full.
- Gland packing seal (standard)**
- P6 type**
- Inside tank temperature: 120°C or less
 - Inside tank pressure: 0.1 MPaG (1.0 kgf/cm²G) or less

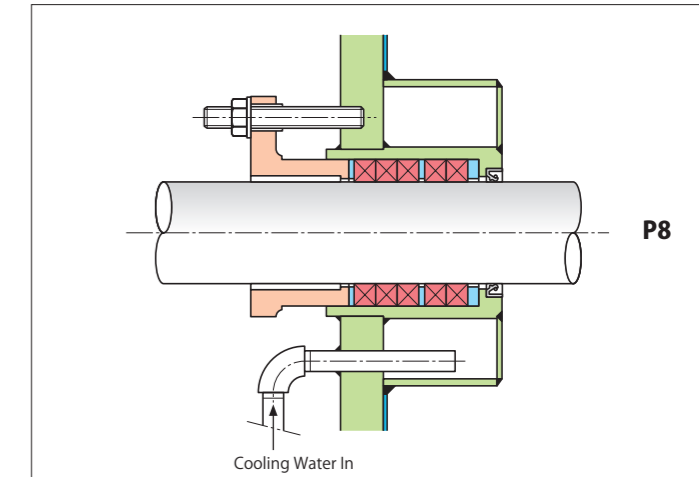

- Gland packing seal (forced cooling)**
- P8type**
- Inside tank temperature: Between 121°C and 170°C
 - Inside tank pressure: 0.1 MPaG (1.0 kgf/cm²G) or less
 - A jacket is provided at the seal for cooling water to pass through, if the temperature in the tank exceeds 121°C or higher.

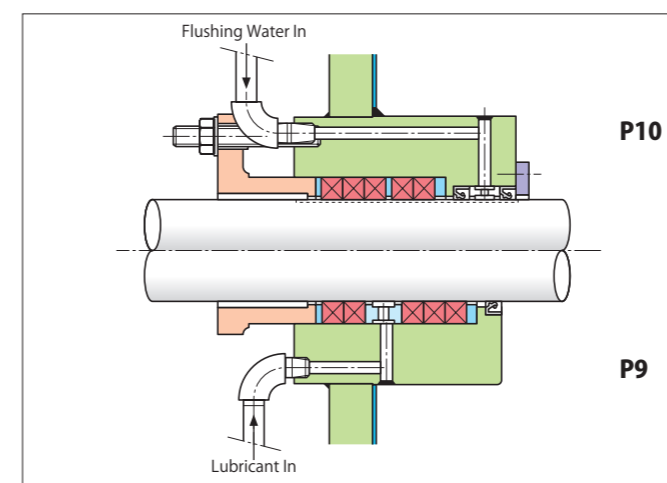

- Gland Packing Seal (for slurry application)**
- P10 type**
- Inside tank temperature: 120°C or less
 - Inside tank pressure: 0.1 MPaG (1.0 kgf/cm²G) or less
 - Conduct surface hardening treatment on the shaft at the seal area, and inject flushing water (2 to 3 ℓ/min) into the tank to prevent slurry liquid from entering the seal area.
- Gland Packing Seal**
- P9 type**
- Inside tank temperature: 120°C or less
 - Inside tank pressure: 0.1 MPaG (1.0 kgf/cm²G) or less
 - Inject lubricant periodically in the midsection of the gland packing. Seal the leaking fluid with the packing at the back of the lantern ring and the lubricant with the packing at the front.

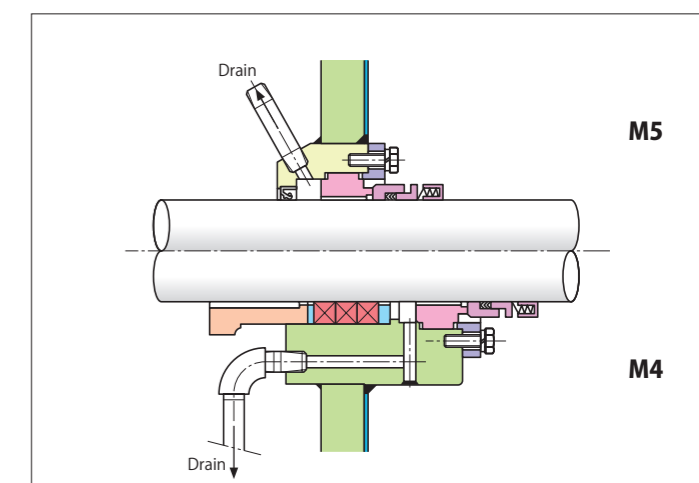

- Single Mechanical Seal**
- M5 type**
- Inside tank temperature: 120°C or less
 - Inside tank pressure: 0.3 MPaG (3.0 kgf/cm²G) or less
 - It is generally used in applications where leakage is not tolerated, and provides excellent sealing performance.
- Single Mechanical Seal + Gland Packing Seal**
- M4 type**
- Inside tank temperature: 120°C or less
 - Inside tank pressure: 0.3 MPaG (3.0 kgf/cm²G) or less
 - The gland packing seals the liquid in the tank when the mechanical seal starts to leak.

* Single mechanical seal with a temporary seal is also available.

Easy, convenient, and durable

– Your ease-of-use is our top priority.

Swing replacement mechanical seal type (E1 type)

1. The mechanical seal can be easily replaced without removing the gear reducer of the mixer, with a simple device and preliminary operation, even in a low-ceiling area.
2. The mechanical seal unit can be pulled out right above the gear reducer without being blocked, as the gear reducer swings horizontally.
3. Maintenance time will be significantly reduced, leading to a shorter shutdown time and higher operating rates.
4. In case you do not have the equipment to lift the mechanical seal unit, you can use the optional winch with a simple support to lift and remove it.
5. The entire mechanical seal unit can be removed for disassembly, repair, and reassembly in a safe place, and leak tests can be performed securely.
6. We also offer a simple mechanical seal detachable mixer without the swivel mechanism of the gear reducer part (Figure 3 below). The reducer part can be removed with a winch which is installed at the installation site of the mixer, and the unit can be detached. (Note: The rest of the mechanism is the same.)

Features of Mechanical Seal

The mechanical seal is generally used in applications where leakage is not tolerated and provides excellent sealing performance even under high temperature and high pressure.

1. Almost no leakage.
2. The sliding area is small due to end-face contact, and the friction coefficient is small, resulting in low power consumption.
3. No damage to the drive shaft.
4. Can be used in high PV value conditions
5. It is designed for long-term use, usually lasting 1 to 2 years of continuous operation.
6. Can be used for high temperature liquids (up to about +300°C) if a cooling system is employed. It can also withstand low temperature liquids (-50°C).
7. No additional tightening adjustment is required.

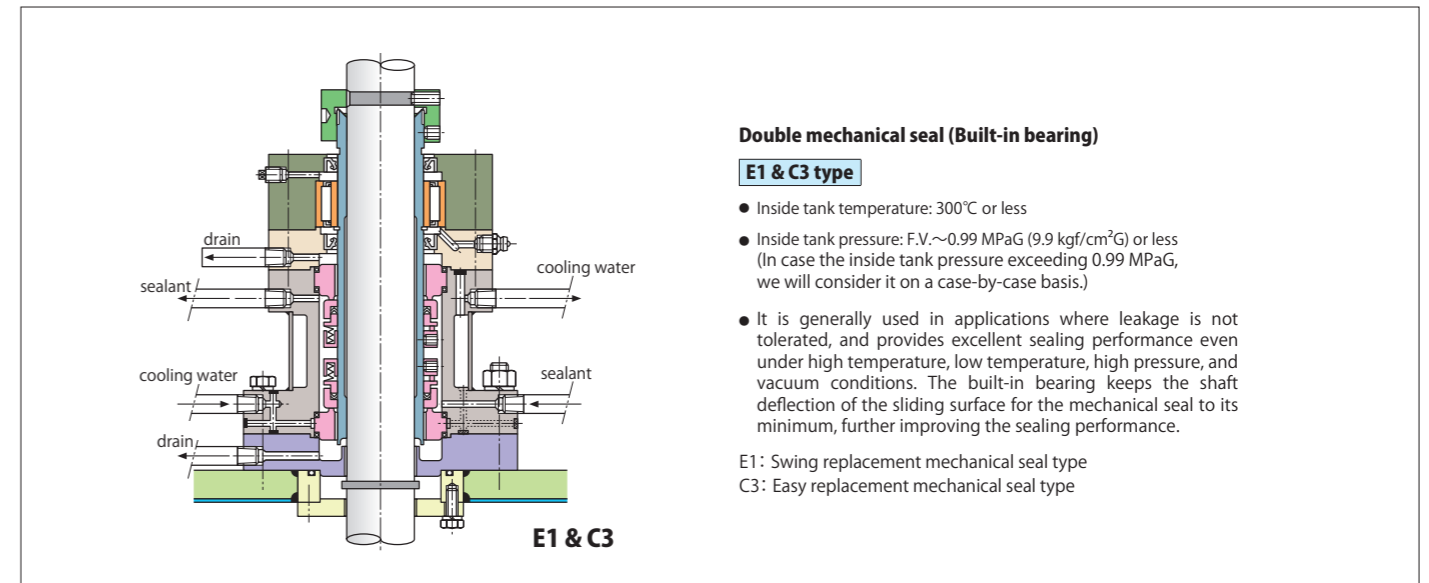

(Perform the reverse process when installing.)

1. Preparation

1. Set the tank pressure to normal. (Hazardous gases must be replaced in the container)
2. Install the set plate ① on the mechanical seal sleeve.
3. Loosen the sleeve set collar ②.
4. Loosen the rigid coupling connecting bolts ③.
5. Loosen the adapter frame connecting bolts ④.

2. Lifting up

1. Tighten the lifting bolts ⑤ on the adapter frame
2. Tighten the bolts at the bottom of the swivel (rotating ring) ⑥ alternately with the lifting bolts ⑤.
3. The frame and gear reducer will separate from one another.

3. Turn

- Use the swivel ⑦ as a support point, push the reducer by hand, and turn gently.

4. Removal

- Remove the rigid coupling ⑧ directly upward.
- Remove the seal unit ⑨ directly upward, while leaving the drive shaft on the stopper at the lower end of the flange.

※ In case you want to operate the temporary seal and replace the seal while maintaining the internal pressure of the tank, we provide this as an option. Please specify it.

Mechanical seals can be easily replaced, leading to energy savings and operational efficiency.

Standard Dimensional Drawings for Swing Replacement Mechanical Seal Type (E1)-Top-mount Type

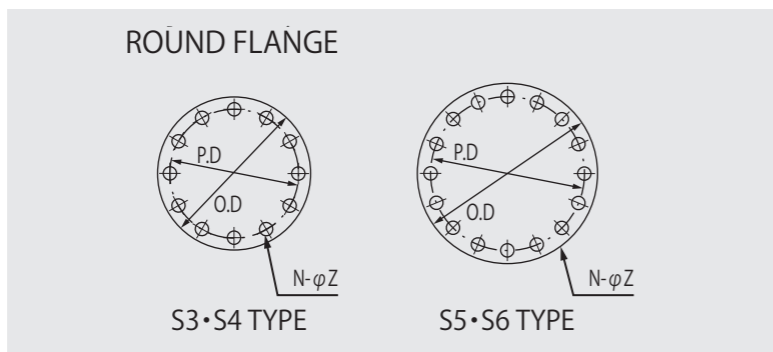
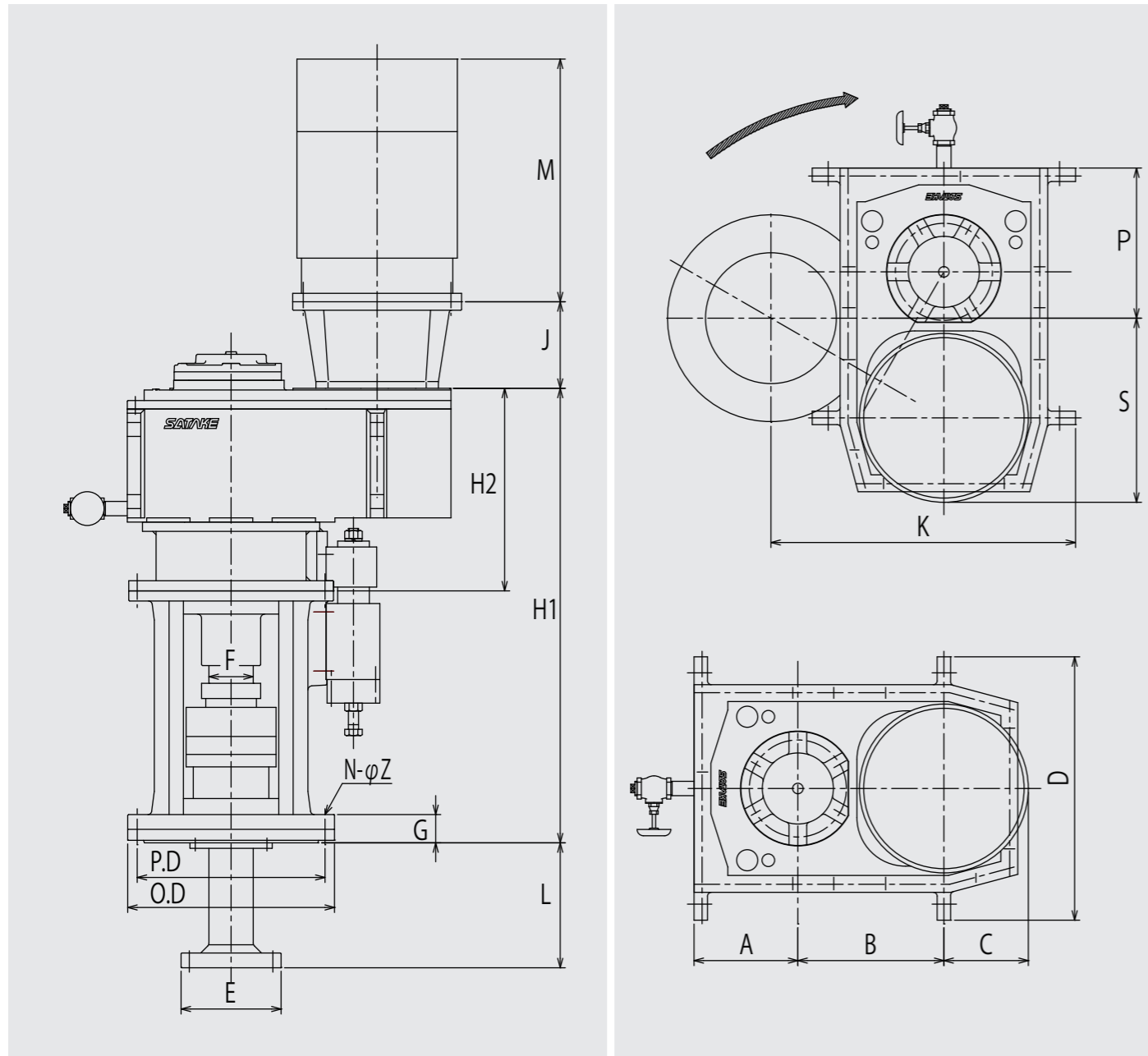

We are constantly committed to improve the quality of our products, thereby the design and specifications of our products may differ from those shown in the catalog. Please understand this in advance.

Standard Dimensions for Swing Replacement Mechanical Seal Type (E1)-Top-mount Type

	Series	Motor Power (kW)		Dimensions (mm)																	Mixer Body				
		4P	6P	O.D	P.D	G	N	ΦZ	F	E	L	H1	H2	J*	A	B	C*	D	K	P	S*	M**	Estimated weight	Motor weight	
Single-stage gear reducer	S3	5.5	3.7	350	310	59	12	23	55	137	200	766	367	-	162	119	214	426	479	220	262	400	365	(80)	
		7.5	5.5	350	310	59	12	23	55	137	200	766	367	-	162	119	214	426	479	220	262	400	365	(80)	
	S4	11	7.5	400	355	61	12	25	65	157	200	806	462	-	175	138	216	480	547	257	272	485	490	(110)	
		15	11	400	355	61	12	25	65	157	200	806	462	-	175	138	216	480	547	257	272	525	510	(130)	
		18.5	15	445	400	61	16	25	85	207	250	1,011	515	-	208	176	251	549	620	301	335	575	780	(195)	
	S5	22	18.5	445	400	61	16	25	85	207	250	1,011	515	-	208	176	251	549	620	301	335	575	800	(195)	
30		22	445	400	61	16	25	85	207	250	1,011	515	-	208	176	251	549	620	301	335	615	810	(225)		
18.5		15	445	400	61	16	25	85	207	250	1,011	515	-	208	176	251	549	620	301	335	575	800	(195)		
2-stage gear reducer 3-stage gear reducer	S3	0.75	-	350	310	59	12	23	55	137	200	681	272	-	162	224	109	426	479	220	262	260	290	(17)	
		1.5	-	350	310	59	12	23	55	137	200	681	272	-	162	224	109	426	479	220	262	312	295	(24)	
		2.2	-	350	310	59	12	23	55	137	200	681	272	12	162	224	109	426	479	220	278	328	300	(30)	
		3.7	-	350	310	59	12	23	55	137	200	681	272	12	162	224	109	426	479	220	278	355	330	(48)	
	S4	0.75	-	400	355	61	12	25	65	157	200	770	329	-	175	239	115	480	547	257	272	260	365	(17)	
		1.5	0.75	400	355	61	12	25	65	157	200	770	329	-	175	239	115	480	547	257	272	312	370	(24)	
		2.2	1.5	400	355	61	12	25	65	157	200	770	329	12	175	239	115	480	547	257	272	328	380	(30)	
		3.7	-	400	355	61	12	25	65	157	200	770	329	12	175	239	115	480	547	257	272	282	355	395	(48)
		5.5	-	400	355	61	12	25	65	157	200	770	329	18	175	239	115	480	547	257	307	400	430	(80)	
	S5	2.2	1.5	445	400	61	16	25	85	207	250	885	389	12	208	287	150	549	620	301	335	328	560	(30)	
		3.7	2.2	445	400	61	16	25	85	207	250	885	389	12	208	287	150	549	620	301	335	355	580	(48)	
		5.5	-	445	400	61	16	25	85	207	250	885	389	18	208	287	150	549	620	301	344	400	610	(80)	
7.5		-	445	400	61	16	25	85	207	250	885	389	18	208	287	150	549	620	301	344	400	610	(80)		
11		-	445	400	61	16	25	85	207	250	885	389	18	208	287	150	549	620	301	369	485	630	(110)		
15		-	445	400	61	16	25	85	207	250	885	389	18	208	287	150	549	620	301	369	525	650	(130)		
S6	5.5	3.7	560	510	71	16	27	105	237	300	1,076	480	18	251	346	624	722	356	411	400	970	(80)			
	7.5	5.5	560	510	71	16	27	105	237	300	1,076	480	18	251	346	624	722	356	411	400	970	(80)			
	11	-	560	510	71	16	27	105	237	300	1,076	480	18	251	346	624	722	356	411	485	960	(110)			
	15	-	560	510	71	16	27	105	237	300	1,076	480	18	251	346	624	722	356	411	525	1,010	(130)			
	18.5	-	560	510	71	16	27	105	237	300	1,076	480	205	251	346	624	722	356	436	575	1,130	(195)			
	22	-	560	510	71	16	27	105	237	300	1,076	480	205	251	346	624	722	356	436	615	1,160	(225)			

* The dimensions J, C and S in the table are calculated based on the totally-enclosed-fan-cooled motor for outdoor use. However, the dimensions J, C and S may vary for the increased-safety explosion-proof motor for motor power of 22kW and above. Also, these dimensions may vary depending on the motor brand.

** The dimension M and estimated weight of mixer's main body are based on the totally-enclosed-fan-cooled motor for outdoor use.

We are dedicated to manufacture products that satisfy our customers and are safe to use.



SATAKE CHEMICAL EQUIPMENT MFG., LTD.

Tokyo office and plant	66, Niizo, Toda-shi, Saitama 335-0021, Japan TEL: 81-48-433-8711 FAX: 81-48-433-8541
Osaka office and plant	2-18-8 Toko-cho, Moriguchi-shi, Osaka 570-0035, Japan TEL: 81-6-6992-0371 FAX: 81-6-6998-4947
Chubu sales service center	1-21-9 Heiwa, Naka-ku, Nagoya-shi, Aichi 460-0021, Japan TEL: 81-52-331-6691 FAX: 81-52-331-2162
Mixing technology laboratory	60, Niizo, Toda-shi, Saitama 335-0021, Japan TEL: 81-48-441-9200 FAX: 81-48-444-1042

(overseas associated company)

China	Satake (Shanghai) Trading Co., Ltd. Room 605, Huaihaizhonghua Buiding, 885. Renmin Road, Shanghai 200010, China TEL: 86-21-6437-7101
	Dalian Satake Chemical Equipment Co., Ltd. No.8 Qingdao Road, Lushun Economic Development Zone, Dalian 116052, China TEL: 86-411-3936-8689-8001 FAX: 86-411-3936-8690
Korea	Hado Co., Ltd. 95, Gajaeul-ro, Seo-Gu, Incheon, 22830, Korea TEL: 82-32-583-6321 FAX: 82-32-583-6329
Taiwan	Kwan-Tai Machinery Co., Ltd. 25, Ln. 227, Fuxing Rd., Luzhou District, New Taipei City 24744, Taiwan TEL: 886-2-2281-9166 FAX: 886-2-2282-4946
Malaysia	Satake Multimix (M) Sdn. Bhd. SB-10-07 Menara Paragon, Persiaran Bestari Cyberjaya, 63000 Cyberjaya, Selangor, Malaysia TEL: +603-3310-0888

<https://www.satake.co.jp/en/>
info@satake.co.jp



Scope of review:

Development, design, manufacture, repair, and sales management of mixing devices

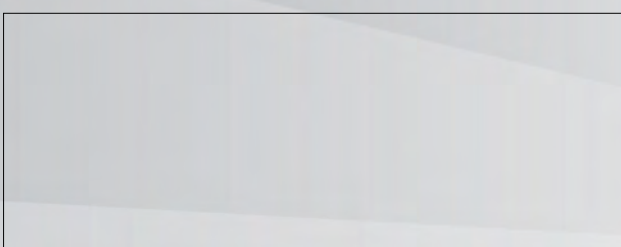
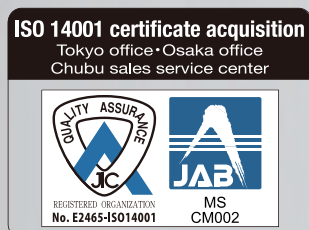

Satake Multi-S Mixer® and Supermix® are registered trademarks of Satake Chemical Equipment MFG., Ltd.
We are constantly committed to improve the quality of our products, thereby the design and specifications of our products may differ from those shown in the catalog. Please understand this in advance.